



MINI CONVEYOR BELT

COMPACT SOLUTION FOR
SMALL PARTS

Conveyor technology



MINI CONVEYOR BELT - SMALL SPACE REQUIREMENT, MAXIMUM FLEXIBILITY

Small parts transport with small space requirement

The Mini conveyor belt is characterized by a very small space requirement and is used to transport small parts. The core component is a special 45 aluminum profile (Profile 45 FRS), which can be seamlessly integrated into any MiniTec construction. It acts as a base and carrier profile for a 25 mm wide conveyor belt, which is available in the following variants:

1. white, PU fabric impregnated, antistatic
2. black, fabric, ESD capable
3. light blue, PU cover, matt, antistatic

The length of the conveyor belt can be between 250 mm and 2000 mm.

Either a head drive or a center drive is used as the drive, i.e. it can be placed at the end of the conveyor line or within it. The head drive is equipped with a servo motor, for the center drive either a three-phase motor or a servo motor can be taken. The choice of motor depends on the specific requirements.

If the speed is to be variable, servo motors are recommended, because with these it can be changed continuously. With three-phase motors, on the other hand, the speed is fixed, but can optionally be varied here as well by means of a frequency converter (accessory).

Various fields of application

The range of applications for the new mini conveyor belt is huge. Wherever small parts have to be transported, the solution can be integrated quickly and easily - due to its simple design, of course, also by the customer himself. And because the 45 FRS profile serves as the basis, mini conveyor belts can also be used to feed or discharge materials in combination with MiniTec's FRS kanban system.



29.5400/0



29.5400/1

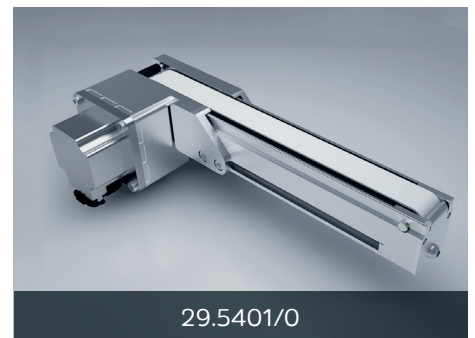

29.5401/0

Mini conveyor belt center drive with servo motor

- 25 mm belt width
- Servo drive with spur gear, 60W
- Left / right rotation switchable at the driver, or via external control (reversing operation)
- Conveying speed continuously adjustable from 0.5 - 25 m/min
- Determine position of drive via L1 (min. 50mm) & L2 (min. 50 mm):
 $A = L1 + L2 + 128 \text{ mm}$

Mini conveyor belt center drive with three phase motor

- 25 mm belt width
- Drive via three-phase motor with 90 W:
3.4 m/min belt speed
4.3 m/min belt speed
6.6 m/min belt speed
- Left / right rotation by corresponding terminal assignment on the motor
- Determine position of drive via L1 (min. 50mm) & L2 (min. 50 mm):
 $A = L1 + L2 + 128 \text{ mm}$

Mini conveyor belt head drive with servo motor

- 25 mm belt width
- Servo drive with spur gear, 60W
- Conveying speed continuously adjustable from 0.4 - 20 m/min